

## VT Solar House

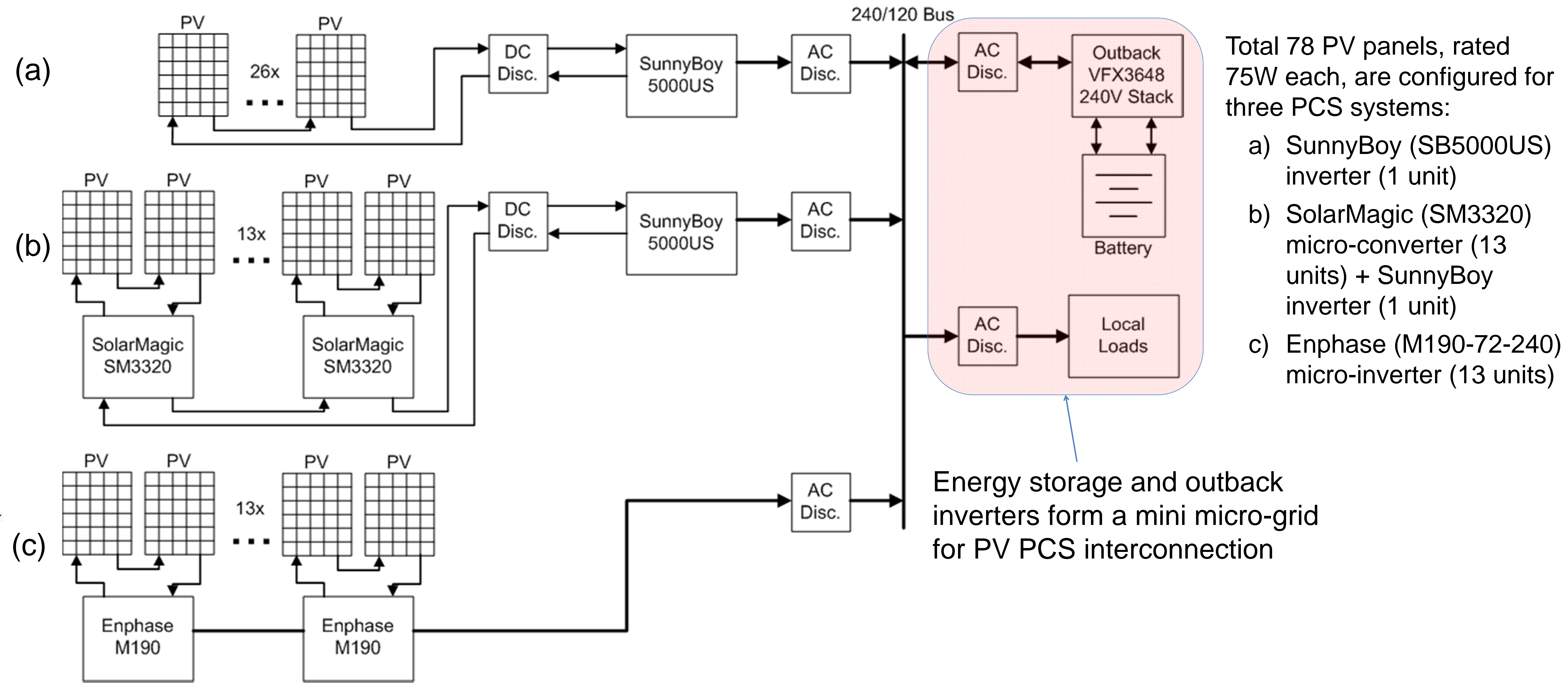

## Communication Setup



## FEEC Solar Energy Production with Three PCS Configurations Shown on Google PowerMeter™

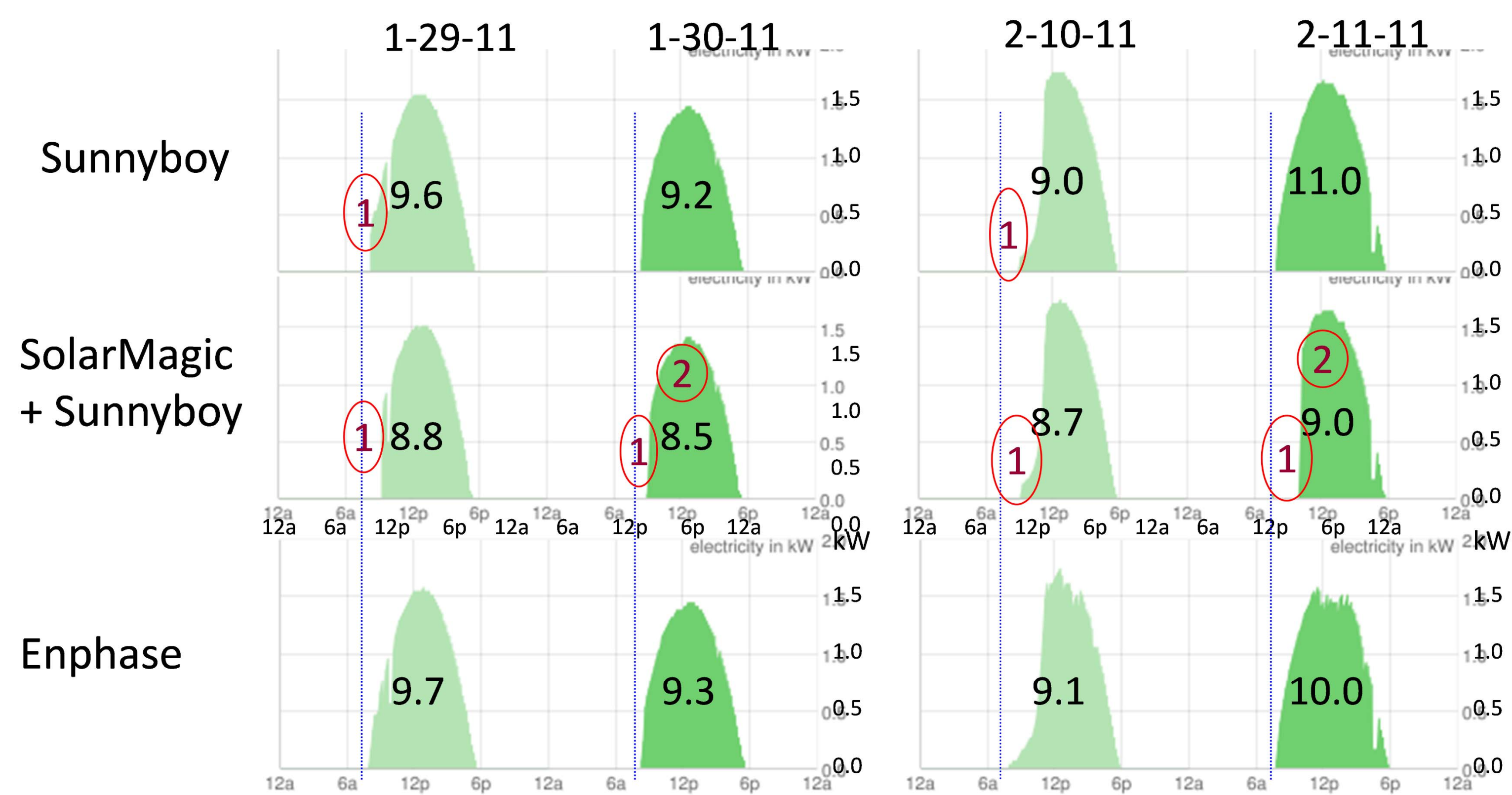

PCS design can impact energy production with following factors:

- (1) Morning startup
- (2) PCS efficiency

## PCS Power Output and Energy Production (01/30/2011, Mostly Sunny, 63°F Peak)

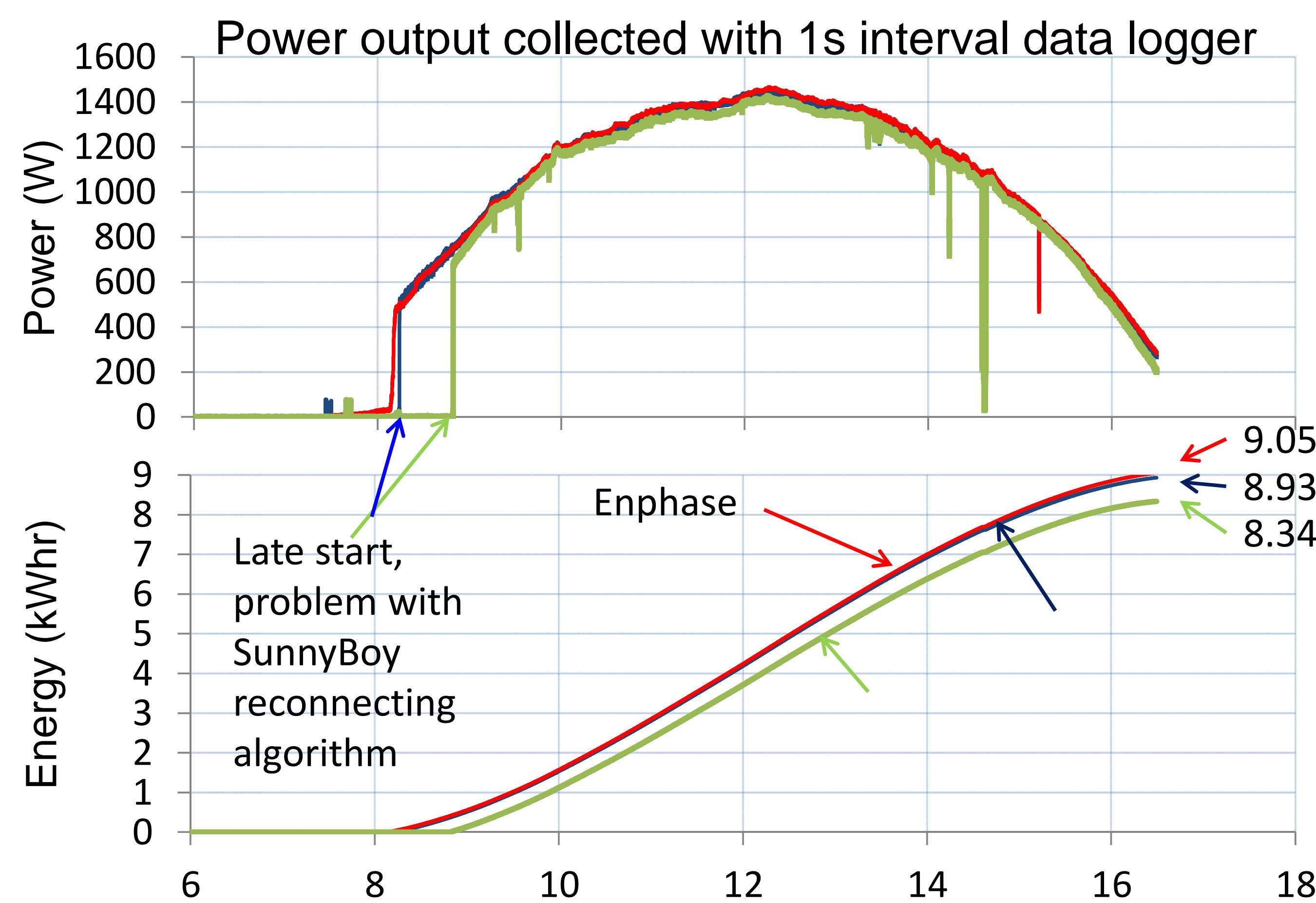

Late start showing significant energy production deficiency with the Sunnyboy inverter design

## Statistic Energy Production over 4-Week Period

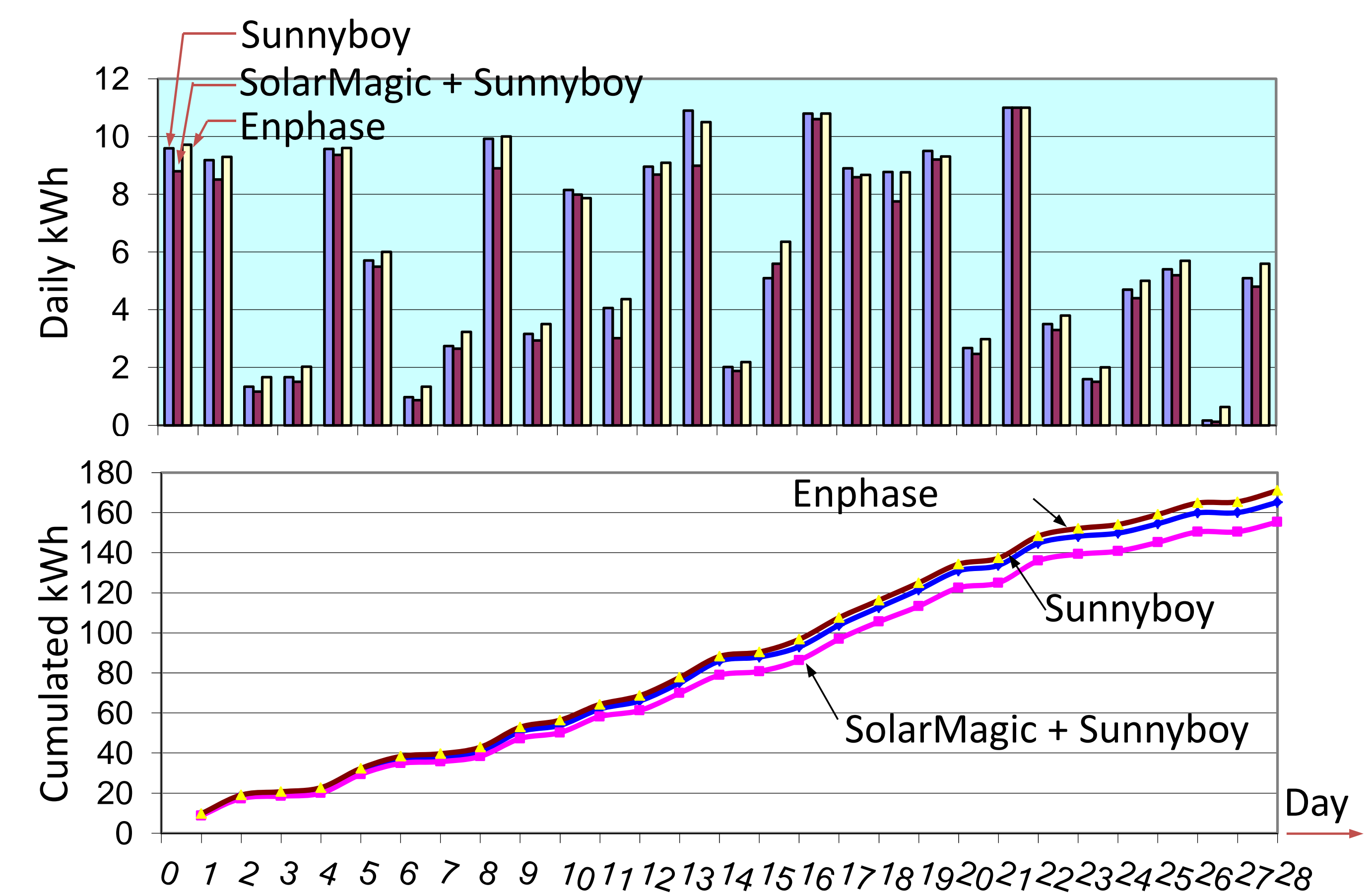

- In general, the Enphase inverter produces more energy. A few exceptions are observed, which are most likely caused by the cloud.
- The SunnyBoy inverter normally produces more energy than SolarMagic + SunnyBoy. One exception is observed, which is due to late reconnection of the inverter.